

Z 4292

Schiebereinheiten
Slide units
Unités de tiroirs

STRACK[®]
NORMALIEN

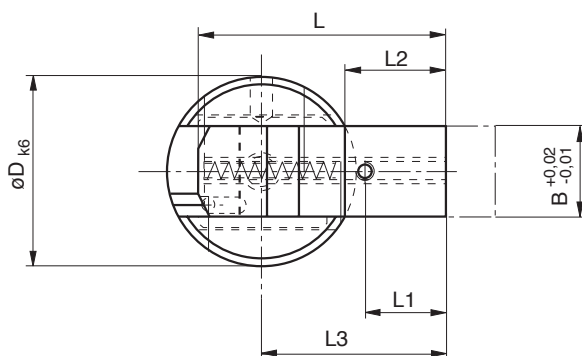
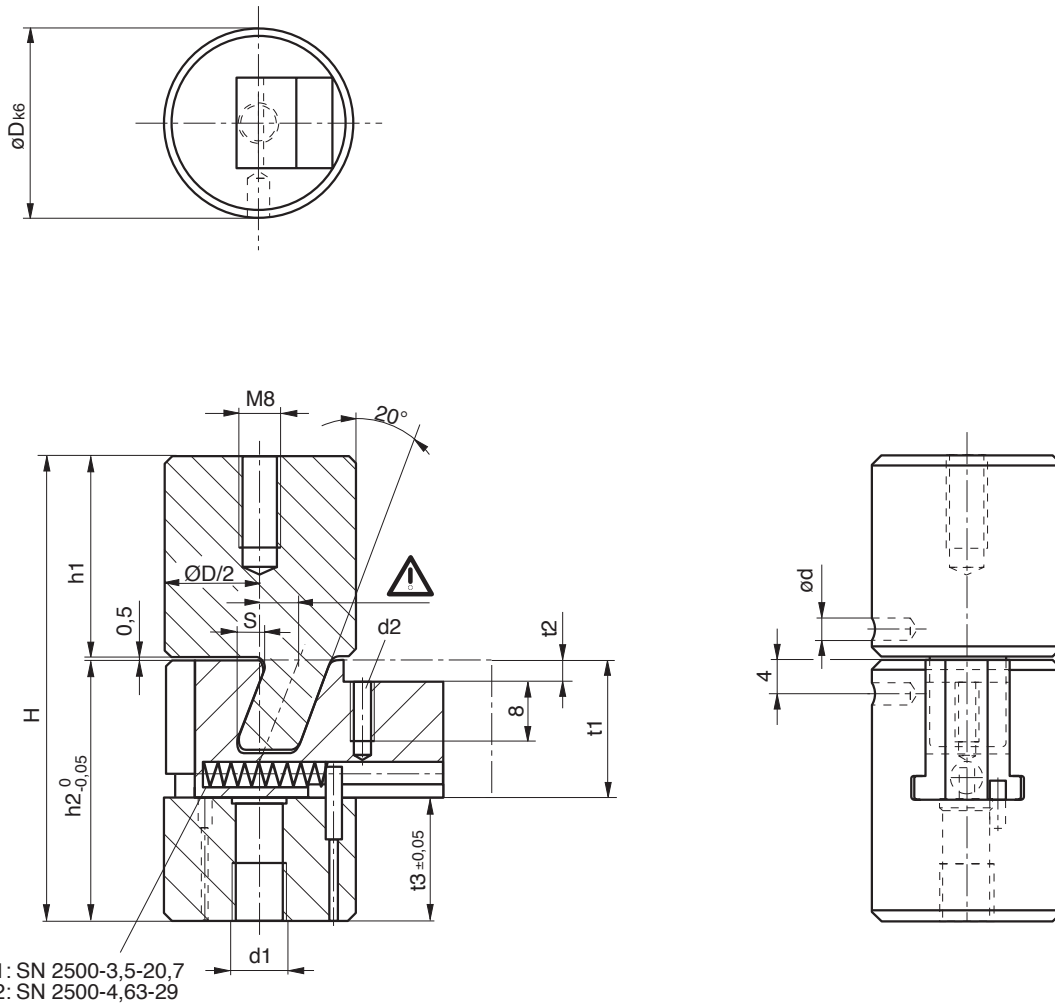

 **Z 4292-**

 Z 4290-Type

Mat.-Nr. 1.2343/52 HRC

Type	D	B	S	H	h1	h2	t1	t2	t3	L	L1	L2	L3	d	d1	d2	
1	25	11	3,4	61,5	26,5	34,5	18	2,5	16,5	32,8	10,8	13,9	24,2	3	M6	M3	
2	40	22	6,4	60,5	20,0	40,0	28	8,0	12,0	50,0	8,0	20,0	37,0	4	M8	M5	

