

D

C

B

A

A - A

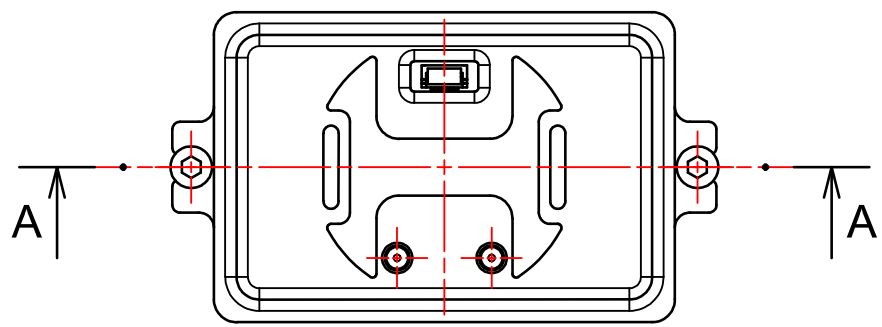
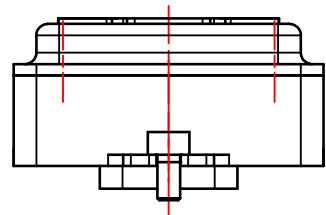
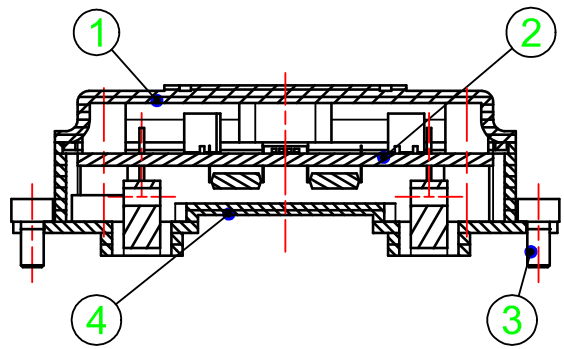

Eclaté du module

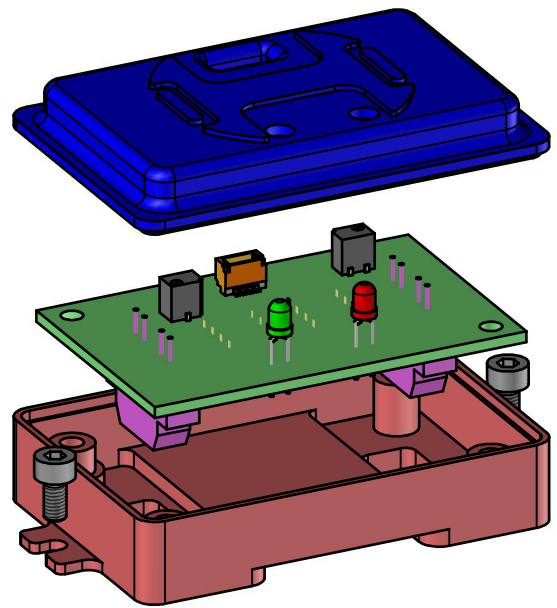

| | | | | |
|--------|-----|-------------------------|-------------------------------------|--------------|
| 4 | 1 | Boîtier inférieur | acrylonitrile-butadiène-styrène ABS | - |
| 3 | 2 | vis C HC M3-6 | acier | - |
| 2 | 1 | Carte de suivi de ligne | - | - |
| 1 | 1 | Boîtier supérieur | acrylonitrile-butadiène-styrène ABS | - |
| REPÈRE | NB. | DESIGNATION | MATIERE | OBSERVATIONS |

| | | | |
|-----------------------|---------------------------------|--------------------------------|----------|
| ÉCHELLE 1:1 | Module de suivi de ligne | AUTEUR B. PERROT, J. POIROT | 1 |
| | | DATE 20/04/2008 | |
| | TopSolid | LGT LIVET | Adresse1 |
| A4 | NUMÉRO DU DOCUMENT | | Adresse2 |
| | | | 00 |

D

C

B

A